



GROUND FORCE®
DRIFTER



OWNER'S MANUAL

⚠ Read and understand this entire manual BEFORE riding!

NOTE: Manual illustrations are for demonstration purposes only. Illustrations may not reflect exact appearance of actual product. Specifications subject to change without notice.

For assistance contact Razor. DO NOT RETURN TO STORE.

CONTENTS

Safety Warnings	1	Troubleshooting Guide.....	8
Before You Begin.....	2	Ground Force Drifter Parts	10-11
Assembly and Set-Up.....	3-6	Safety Reminders.....	12
Repair and Maintenance.....	7	Warranty	12

SAFETY WARNINGS

⚠ WARNING: Riding an electric product can be a hazardous activity. Certain conditions may cause the equipment to fail without fault of the manufacturer. Like other electric products, the Ground Force Drifter can and is intended to move, and it is therefore possible to lose control, fall off and/or get into dangerous situations that no amount of care, instruction or expertise can eliminate. If such things occur you can be seriously injured or die, even when using safety equipment and other precautions. **RIDE AT YOUR OWN RISK AND USE COMMON SENSE.**

This manual contains many warnings and cautions concerning the consequences of failing to maintain, inspect or properly use your electric product. Because any incident can result in serious injury or even death, we do not repeat the warning of possible serious injury or death each time such a possibility is mentioned.

APPROPRIATE RIDER USE AND PARENTAL SUPERVISION

This manual contains important safety information. It is your responsibility to review this information and make sure that all riders understand all warnings, cautions, instructions and safety topics and assure that young riders are able to safely and responsibly use this product. Razor USA recommends that you periodically review and reinforce the information in this manual with younger riders, and that you inspect and maintain your children's product to insure their safety.

The recommended rider age of 8 years or older is only an estimate and can be affected by the rider's size, weight or skills. Any rider unable to fit comfortably on the Ground Force Drifter should not attempt to ride it.

A parent's decision to allow his or her child to ride this product should be based on the child's maturity, skill and ability to follow rules.

Keep this product away from small children and remember that this product is intended for use only by persons who are, at a minimum, completely comfortable and competent while operating the product.

DO NOT EXCEED THE WEIGHT LIMIT OF 140lbs (64kg). Rider weight does not necessarily mean a person's size is appropriate to fit or maintain control of the Ground Force Drifter.

Do not touch the brakes or electric motor on your electric product when in use as they can become very hot.

Refer to the following section on safety for additional warnings.

ACCEPTABLE RIDING PRACTICES AND CONDITIONS

Always check and obey any local laws or regulations which may affect the locations where the Ground Force Drifter may be used.

Ride defensively. Watch out for potential obstacles that could catch your wheel or force you to swerve suddenly or lose control. Be careful to avoid pedestrians, skaters, skateboards, scooters, bikes, children or animals who may enter your path, and respect the rights and property of others.

The Ground Force Drifter is meant to be used on private property and on closed courses and not on public streets or sidewalks. Do not ride your electric product in any areas where pedestrian or product traffic is present.

Do not activate the throttle unless you are on the product and in a safe, outdoor environment suitable for riding.

This product was manufactured for performance and durability, but is not impervious to damage. Jumping or other aggressive riding can over-stress

and damage any product, including the Ground Force Drifter, and the rider assumes all risks associated with high-stress activity.

Be careful and know your limitations. Risk of injury increases as the degree of riding difficulty increases. The rider assumes all risk associated with aggressive riding activities.

Maintain a hold on the steering wheel at all times.

Never carry passengers or allow more than one person at a time to ride the electric product.

Never use near steps or swimming pools.

Keep your fingers and other body parts away from the drive chain, steering system, wheels and all other moving components.

Never use headphones or a cell phone when riding.

Never hitch a ride with another product.

Do not ride the Ground Force Drifter in wet or icy weather and never immerse the electric product in water, as the electrical and drive components could get damaged by water or possibly create other unsafe conditions.

Wet, slick, bumpy, uneven or rough surfaces may increase risks. Do not ride the electric product in mud, ice, puddles or water. Avoid excessive speeds that can be associated with downhill rides. Never risk damaging surfaces such as carpet or flooring by using an electric product indoors.

Do not ride at night or when visibility is limited.

PROPER RIDING ATTIRE

Always wear proper protective equipment such as an approved safety helmet (with chin strap securely buckled). A helmet may be legally required by local law or regulation in your area. Elbow pads and kneepads, a long-sleeved shirt, long pants and gloves are recommended. Always wear athletic shoes (lace-up shoes with rubber soles), never ride barefooted or in sandals and keep shoelaces tied and out of the way of the wheels, motor and drive system.

USING THE CHARGER

The charger supplied with the electric product should be regularly examined for damage to the cord, plug, enclosure and other parts. In the event of such damage, the product must not be charged until the charger has been repaired or replaced.

Use only with the recommended charger.

Use caution when charging.

The charger is not a toy. Charger should be operated by an adult.

Do not operate charger near flammable materials.

Make sure power switch is in the "off" position, unplug charger and disconnect from product when not in use.

Do not exceed charging time.

Always disconnect from the charger prior to wiping down and cleaning your scooter with liquid.

FAILURE TO USE COMMON SENSE AND HEED THE ABOVE WARNINGS INCREASES RISK OF SERIOUS INJURY. USE WITH APPROPRIATE CAUTION AND SERIOUS ATTENTION TO SAFE OPERATION.

BEFORE YOU BEGIN

Remove contents from box. Remove the foam separators that protect the components from damage during shipping. Inspect the contents of the box for scratches in the paint, dents or kinked cables that may have occurred during shipping. Because the Ground Force Drifter was 95 percent assembled and packed at the factory, there should not be any problems, even if the box has a few scars or dents.

Estimated Assembly and Set-Up Time

Razor recommends assembly by an adult.
 Allow up to 45 minutes for assembly, not including initial charge time.
 Allow up to 12 hours for initial charge (see page 5 for charging information).

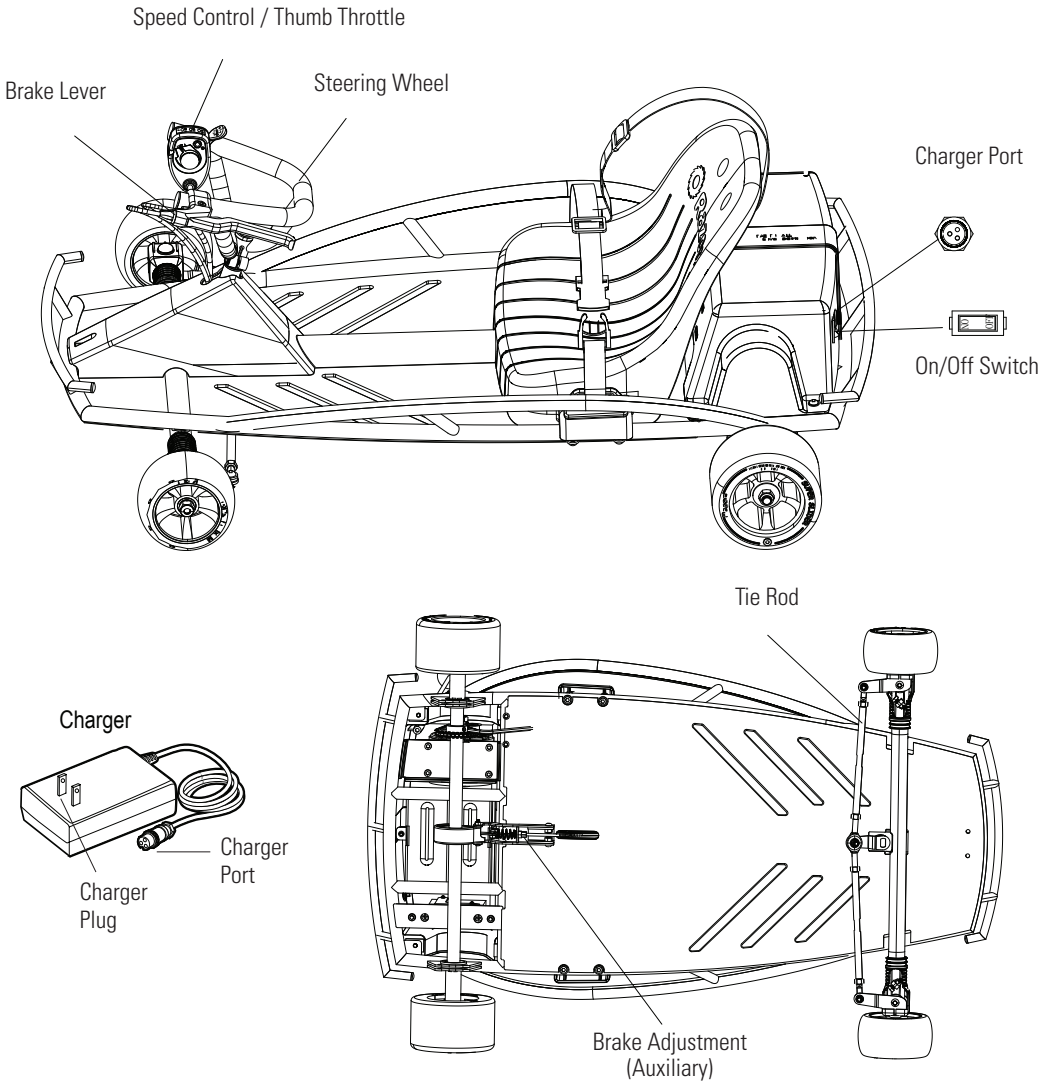

⚠ WARNING:
DO NOT USE NON-RAZOR PARTS WITH YOUR GROUND FORCE DRIFTER. The Ground Force Drifter has been built to certain Razor design specifications. The original equipment supplied at the time of sale was selected on the basis of its compatibility with the frame and all other parts. Certain aftermarket components may not be compatible. Use of non-Razor parts will void the warranty.

⚠ WARNING: Turn power switch off before conducting any maintenance procedures.

☐ Required Tools

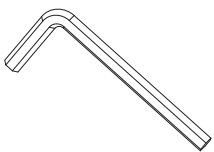

(2) 5mm Allen wrench (included)
 3mm Allen wrench (not included)

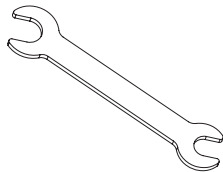

8/10mm open wrench
 (not included)

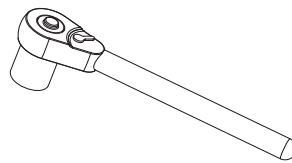

13/17mm wrench
 (not included)

Need Help? Visit our web site for replacement parts, product support and a list of authorized service centers at www.razor.com or call toll-free at 866-467-2967 Monday - Friday 8:00 AM - 5:00 PM Pacific Time.

ASSEMBLY AND SET-UP

Turn power switch off before conducting any maintenance procedures.

□ Attaching the Steering Wheel

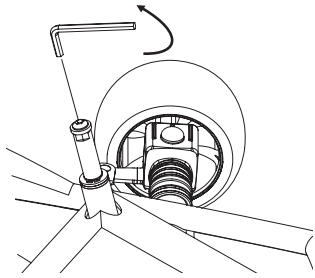

1 Using a 5mm Allen wrench, loosen the screw located in the steering column.

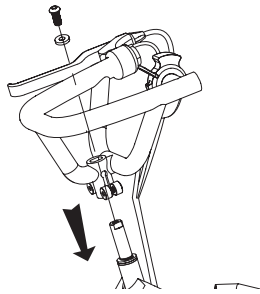

2 Make sure the wires are not tangled. Insert the steering wheel, washer and screw into the steering column as shown.

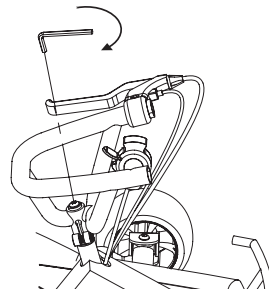

3 Tighten screw **securely** using a 5mm Allen wrench.

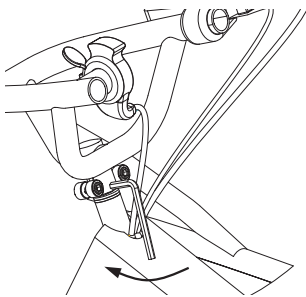

4 Using a 5mm Allen wrench, alternately tighten each of the bolts on the steering wheel clamp. When the bolts are properly tightened, the gap between the clamp halves should be even.

□ Attaching the Seat

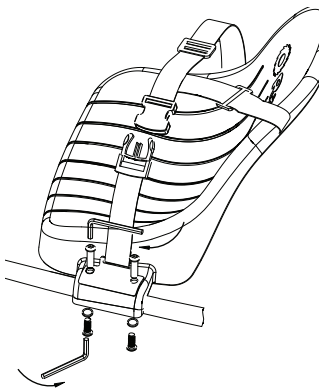

1 Position the seat over the frame and align it with the holes in the frame. Align the safety belt anchor holes to the holes in the seat and frame with the lap/shoulder assembly on the left and the receiver latch on the right. Insert the screws and tighten securely.

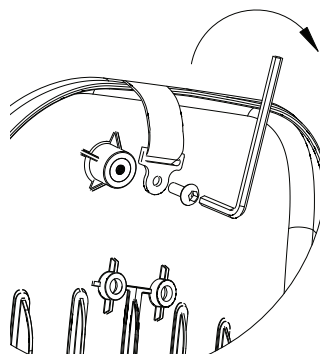

2 Install the shoulder belt anchor to the back of the seat. Insert and tighten securely.

! WARNING: Failure to properly install and tighten the screws, nuts and bolts that affix the steering wheel and seat can cause you to lose control and crash.

! CAUTION: DO NOT flip the Ground Force Drifter upside down to tighten steering axle bolts as it may damage control wires on the steering wheel.

! WARNING: The safety belt arrangement supplied with the Ground Force Drifter is for "play" use only. It is not an ASTM-approved safety belt system and is not intended to function as an approved lap/shoulder/seat restraining device.

Need Help? Visit our web site for replacement parts, product support and a list of authorized service centers at www.razor.com or call toll-free at 866-467-2967 Monday - Friday 8:00 AM - 5:00 PM Pacific Time.

ASSEMBLY AND SET-UP

Turn power switch off before conducting any maintenance procedures.

□ Adjusting the Brake

The brake lever is fitted with a cable adjuster to compensate for cable stretch and/or to fine tune the lever movement to brake engagement.

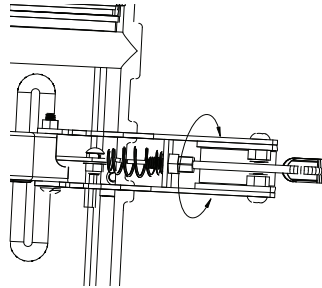
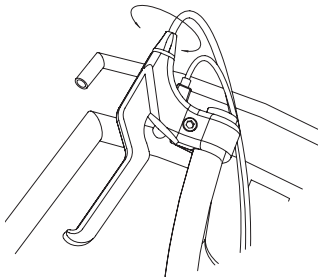

1 To adjust the brake, thread the adjuster in or out 1/4 to 1/2 turns until the desired brake adjustment is attained.

2 If the adjuster is threaded outward and the brake still has too much slack, use the auxiliary adjuster at the rear brake for additional adjustments.

Note: When properly adjusted, the brake lever will have approximately 3mm of free play before the brake engages.

⚠ WARNING: Practice in an open area free from obstacles until you are familiar with the brake function. DO NOT RUN OVER ANY OBJECT AS IT COULD DAMAGE THE BRAKE OR DRIVETRAIN.

□ Self Adjusting Chain Tensioner

Note: Proper alignment of the chain must be maintained. If the chain is adjusted properly, but is noisy or rough running, check alignment of the sprockets. The drive-shaft sprocket can be adjusted slightly from side-to-side by loosening the set screw. Note that a key maintains the drive position to the shaft.

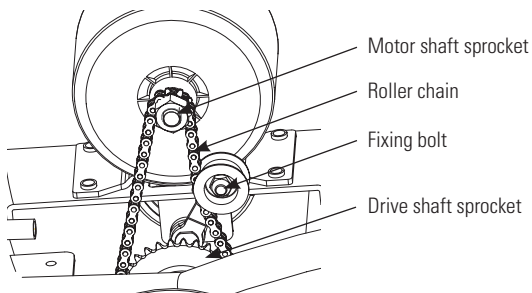

Need Help? Visit our web site for replacement parts, product support and a list of authorized service centers at www.razor.com or call toll-free at 866-467-2967 Monday - Friday 8:00 AM - 5:00 PM Pacific Time.

ASSEMBLY AND SET-UP

Turn power switch off before conducting any maintenance procedures.

□ Charging the Battery

Your Ground Force Drifter may not have a fully charged battery; therefore you must charge the battery prior to use.

- Initial charge time: 12 hours
- Recharge time: 12 hours, even if the light turns green.
- Fully charge battery before storing.
- When the scooter is not in regular use, recharge the battery at least once a month until normal use is resumed.
- Run time: Up to 40 minutes of continuous ride time. Run time may vary depending on riding conditions, climate and/or proper maintenance.
- Average battery life: 250 charge/discharge cycles
- To ensure long battery life, do not store the battery in temperatures above 75° or below -10° F.

Charger

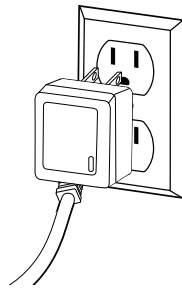
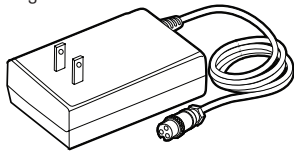

1 Plug the charger plug into wall outlet.

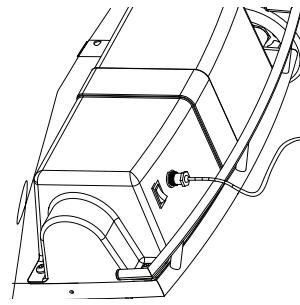

2 Plug the charger into the port on the Ground Force Drifter. Make sure the power switch is in the "OFF" position.

Note: Make sure power is turned **OFF** when unit is not in use. If the power switch is left on for an extended period of time, the battery may reach a stage at which it will no longer hold a charge.

! WARNING: Use **ONLY** with the recommended charger. Batteries are only to be charged under adult supervision. The charger is not a toy. Always disconnect your Ground Force Drifter from the charger before cleaning with liquid.

The charger supplied with the Ground Force Drifter should be regularly examined for damage to the cord, plug, enclosure and other parts. In the event of such damage, the Ground Force Drifter must not be charged until it has been repaired or replaced.

Chargers have built-in over-charge protection to prevent battery from being over-charged.

Note: If the charger gets warm during regular use, this is a normal response and is no cause for concern. If your charger does not get warm during use, it does not mean that it is not working properly.

□ Replacing the Wheels

Front and rear wheel installation and removal are the same.

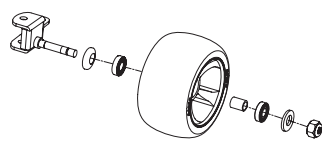
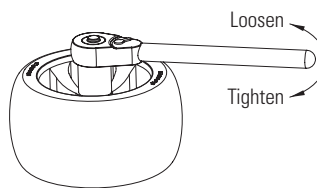

2 Front Wheel: To replace a front wheel, make sure the bearings are seated and the center spacer is installed. Position the wheel with the Razor logo facing outward. Install the washer and tighten the self-locking nut securely.

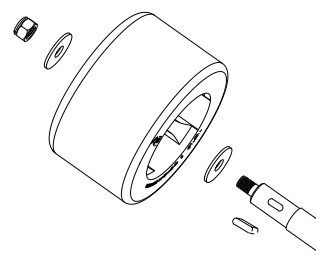

2 Rear Wheel: To replace a rear wheel, make sure the key is properly seated in the rear axle and aligned with the key in the wheel. Position the wheel with the Razor logo facing outward. Install the washer and tighten the self-locking nut securely.

! WARNING: Failure to properly adjust and tighten the screws, nuts and bolts that affix the wheels can cause you to lose control and crash.

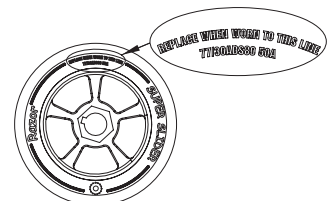

Note: The Ground Force Drifter wheels must be replaced when worn down to the wear indicator line.

Note: Practice drift riding only in wide open areas clear from curbs, parking blocks and other obstacles. Impacting the wheels against any hard surface can damage the wheels. Wheels are not covered under your limited warranty.

Need Help? Visit our web site for replacement parts, product support and a list of authorized service centers at www.razor.com or call toll-free at 866-467-2967 Monday - Friday 8:00 AM - 5:00 PM Pacific Time.

ASSEMBLY AND SET-UP

Turn power switch off before conducting any maintenance procedures. Before you begin, carefully turn unit upside down for easier access.

□ Removing Rear Axle

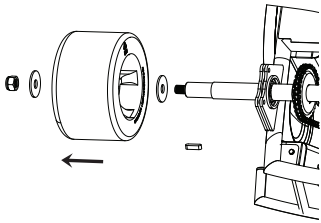

1 Using a 17mm open wrench loosen locknut and remove rear wheel located closest to the chain.

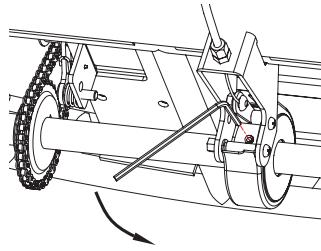

2 Use a 3mm wrench to loosen the brake.

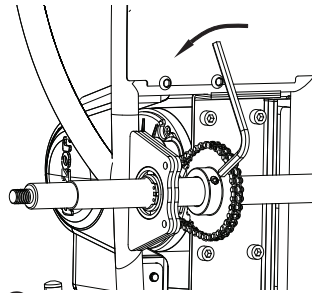

3 Use a 3mm wrench to loosen the sprocket.

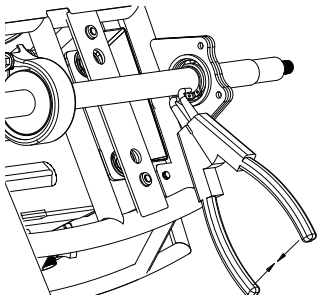

4 Remove c-clips on the axle between the two bearings.

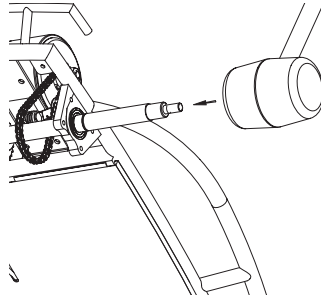

5 Lightly tap the end of the axle with a rubber mallet. DO NOT USE A HAMMER as this will damage the thread. The brake drum and pulley must be slid along the axle as your tapping progresses.

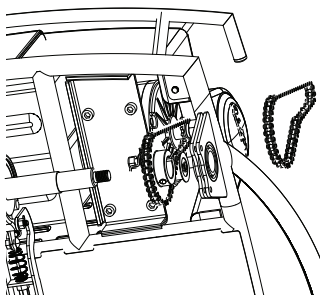

6 When the axle end is clear of the bearing hanger, remove the axle.

□ Replacing the Chain

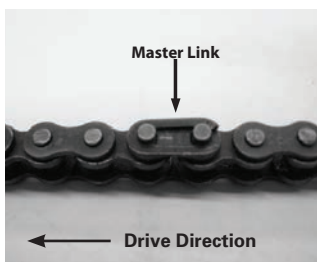

1 Locate the master link on the replacement chain and with a flat head screwdriver carefully disengage the clip from the chain to remove the link plate and connector link.

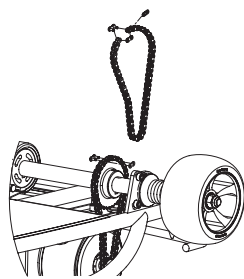

2 Wrap the chain around both sprockets and tension idler. Insert the connector link all the way through the chain and fit the link plate over the connector link.

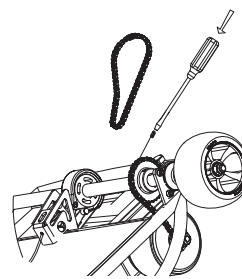

3 Using a flat head screwdriver, carefully re-attach the clip on to the link plate. The clip must point in the drive direction of chain rotation.

Note: Chain should be periodically checked for grime build-up. If necessary remove any dirt and/or debris in and around the chain and re-lubricate with WD-40.

Master Link:



REPAIR AND MAINTENANCE

❑ Battery Care and Disposal

Do not store the battery in temperatures above 75° or below -10° F.



CONTAINS SEALED LEAD ACID BATTERIES. BATTERIES MUST BE RECYCLED.

Disposal: Your Razor product uses sealed lead-acid batteries which must be recycled or disposed of in an environmentally safe manner. Do not dispose of a lead-acid battery in a fire. The battery may explode or leak. Do not dispose of a lead-acid battery in your regular household trash. The incineration, land filling or mixing of sealed lead-acid batteries with household trash is prohibited by law in most areas. Return exhausted batteries to a federal or state approved lead-acid battery recycler or a local seller of automotive batteries. If you live in Florida or Minnesota, it is prohibited by law to throw away lead-acid batteries in the municipal waste stream.

❑ Charger

The charger supplied with the Ground Force Drifter should be regularly examined for damage to the cord, plug, enclosure and other parts and in the event of such damage, the product must not be charged until it has been repaired or replaced.

Use **ONLY** with the recommended charger.

❑ Wheels

Wheels and drive system are subject to normal wear and tear. It is the responsibility of the user to periodically inspect wheels for excess wear and adjust and replace drive train components as required.

❑ Replacement Parts

The most frequently requested replacement parts are available for purchase at some Razor retail partners. For the complete selection of replacement parts visit www.razor.com/shop.

❑ Repair Centers

For a list of authorized Razor repair centers:

- Check online at www.razor.com.
- Call 866-467-2967 for the center nearest you.

⚠ WARNING: If a battery leak develops, avoid contact with the leaking acid and place the damaged battery in a plastic bag. Refer to the disposal instructions at left. If acid comes into contact with skin or eyes, flush with cool water for at least 15 minutes and contact a physician.

⚠ WARNING: Battery posts, terminals and related accessories contain lead and lead compounds. **Wash your hands after handling.**

TROUBLESHOOTING GUIDE

Problem	Possible Cause	Solution
Product does not run.	Undercharged battery.	Charge the battery. A new battery should have been charged for at least 12 hours before using the product for the first time and up to 12 hours after each subsequent use. Check all connectors. Make sure the charger connector is tightly plugged into the charging port and that the charger is plugged into a functioning wall outlet.
	Charger is not working.	Contact Razor Customer Service to get replacement charger.
Product was running but suddenly stopped.	Loose wires or connectors.	Check all wires and connectors to make sure they are tight.
Short run time.	Undercharged battery.	Charge the battery. A new battery should have been charged for at least 12 hours before using the product for the first time and up to 12 hours after each subsequent use.
	Battery is old and will not accept full charge.	Even with proper care, a rechargeable battery does not last forever. Average battery life is 1 to 2 years depending on product use and conditions. Replace only with a Razor replacement battery.
Product runs sluggishly.	Riding conditions are too stressful.	Use only on solid, flat, clean and dry surfaces such as pavement or level ground.
	Product is overloaded.	Make sure you do not overload the product by allowing more than one rider at one time, exceeding the maximum weight limit, going up too steep a hill or towing objects behind the product.
Sometimes the product doesn't run, but other times it does.	Loose wires or connectors.	Check all wires connectors to make sure they are tight.
	Motor or electrical switch damage.	Contact your local Razor authorized service center for diagnosis and repair. Contact Razor customer service or visit www.razor.com
Charger gets warm during use.	Normal response to charger use.	No action required. This is normal for some chargers and is no cause for concern. If your charger does not get warm during use, it does not mean that it is not working properly.
Product makes loud noises or grinding sounds.	Chain is too dry.	Apply a lubricant such as 3 in 1™ or Tri-Flow™ to the chain.

For more troubleshooting tips, visit our website at www.razor.com.

Need Help? Visit our web site for replacement parts, product support and a list of authorized service centers at www.razor.com or call toll-free at 866-467-2967 Monday - Friday 8:00 AM - 5:00 PM Pacific Time.

SB 1918 (CALIFORNIA) DECLARATION

YOUR INSURANCE POLICIES MAY NOT PROVIDE COVERAGE FOR ACCIDENTS INVOLVING THE USE OF THIS SCOOTER/ELECTRIC RIDE-ON PRODUCT. TO DETERMINE IF COVERAGE IS PROVIDED, YOU SHOULD CONTACT YOUR INSURANCE COMPANY OR AGENT.

GROUND FORCE DRIFTER PARTS

Keep your Ground Force Drifter running for years with genuine Razor parts. Visit our web site or e-mail us for more information on spare part availability. (Specifications subject to change without notice.)

01	Steering wheel	20	Washer (x2)
01-1	Screw, M6X16mm for steering wheel (x2)	21	C-clips (x2)
02	Thumb tab throttle	22	Rear axle
03	Brake lever	23	Brake
04	Nut, M8 nylock self locking (x2)	24	Axle sprocket
05	Washer (x2)	25	Chain tensioner
06	Front wheel (x2)	26	Battery (12V / 7Ah) (x2)
07	Front wheel spacer (x2)	27	Universal fuse
07-1	Bearing 608zz 8X22 (x4)	28	Flag
08	Spring washer	29	On/off switch
09	Spindle (right/left)	30	Charger port
10	Protector (x2)	31	Motor cover
11	Steering assembly	32	Seat
12	Axle bearing 6904ZZ 20X37 (x2)	32-1	Coupling bolt
13	Control module	32-2	Washer (x4)
14	Motor GF 250W	32-3	Bolt (x4)
15	Chain	33	Safety belt
16	Nut, M10 nylock self locking & washer (x2)	33-1	Screw, M5*16mm (x2)
17	Washer (x2)	34	Steering cover
18	Rear wheel (x2)	34-1	Screw M5X16 (x4)
19	Key A 5X5X20 (x2)		

Need Help? Visit our web site for replacement parts, product support and a list of authorized service centers at www.razor.com or call toll-free at 866-467-2967 Monday - Friday 8:00 AM - 5:00 PM Pacific Time.

GROUND FORCE DRIFTER PARTS

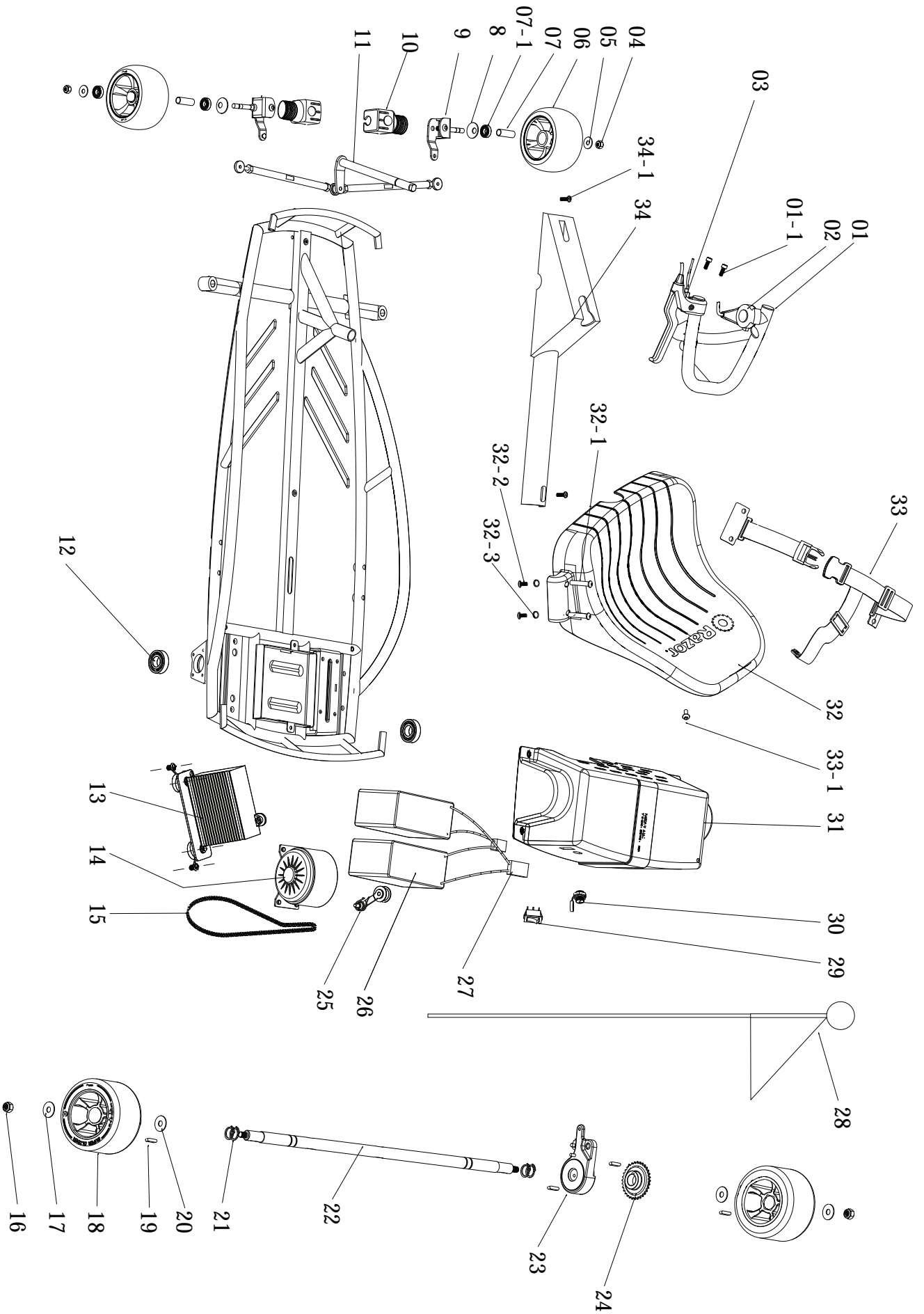

SAFETY REMINDERS

PRE-RIDE CHECKLIST



Loose Parts

Check and secure all fasteners before every ride. There should not be any unusual rattles or sounds from loose parts or broken components. If you are not sure, ask an experienced mechanic to check.



Brake

Check the brake for proper function. When you squeeze the lever, the brake should provide positive braking action. When you apply the brake with the speed control on, the brake cut-off switch will stop the motor.



Wheels

Practice drift driving only in wide open areas clear from curbs, parking blocks and other obstacles. Impacting the wheels against any hard surface can damage the wheels. Wheels are not covered under your limited warranty.



Frame, Fork and Steering Wheel

Check for cracks or broken connections. Although broken frames are rare, it is possible for an aggressive rider to run into a curb or wall and wreck and bend or break a frame. Get in the habit of inspecting yours regularly.



Safety Gear

Always wear proper protective equipment such as an approved safety helmet. Elbow pads and kneepads are recommended. Always wear shoes (lace-up shoes with rubber soles), never drive barefooted or in sandals, and keep shoelaces tied and out of the way of the wheels, motor and drive system.



DO NOT RETURN TO STORE

Do not use this product for the first time until you have charged the battery for at least 12 hours.

Failure to follow these instructions may damage your product and void your warranty.

WARRANTY

Razor Limited Warranty

The manufacturer warrants this product to be free of manufacturing defects for a period of 90 days from date of purchase. This Limited Warranty does not cover normal wear and tear, wheels, cables, or any damage, failure or loss caused by improper assembly, maintenance, storage or use of the Razor Ground Force Drifter.

This Limited Warranty will be void if the product is ever

- used in a manner other than for recreation;
- modified in any way;
- rented.

The manufacturer is not liable for incidental or consequential loss or damage due directly or indirectly to the use of this product.

Razor does not offer an extended warranty. If you have purchased an extended warranty, it must be honored by the store at which it was purchased.

For your records, save your original sales receipt with this manual and write the serial number below.

Item Number:
25143400

Need Help? Visit our web site for replacement parts, product support and a list of authorized service centers at www.razor.com or call toll-free at 866-467-2967 Monday - Friday 8:00 AM - 5:00 PM Pacific Time.

Patent Pending.

Printed in China for:
Razor USA LLC
PO Box 3610
Cerritos, CA 90703

Copyright © 2003 - 2012 Razor USA LLC. All rights reserved. Ground Force, RAZOR and the Razor Logo Design are among the registered trademarks of Razor USA LLC in the United States and/or select foreign countries. Super Slider™ is a trademark of Razor USA LLC.